

Based on a modular design approach, the 36x full-height turnstile range is available with 3 or 4 arms, manual or motorized, single or double passage versions. The TRS361 manual and TRS366 motorized versions belong to this new generation of full-height turnstiles.

Based on a bi-directional access way and a obstacle with a 90° 4-wing configuration, these turnstiles are especially designed to ensure effective, secure, autonomous access control. Their innovative design is suitable for use in all environments. They provide very ergonomic operation and can be fully integrated into any type of site management system (multi-configuration control logic, easy integration of badge readers, videophone, etc.). Their steel structure and durable mechanism, the fruit of over 30 years experience, guarantee that they can withstand prolonged, intensive operation under even the most severe conditions.

Description

Painted modular steel frame:

1. Folded sheet steel uprights with full-height lockable door

– Easy integration of access control equipment

2. Curved panels defining the access passageway, clad with perforated steel plate (6mm hole diameter)

3. Upper box section made of steel sheet steel with a lockable double door for accessing the operating mechanism and the control logic.

4. Tubular steel fixed combs

5. Rotating obstacles made of RAL7038 painted steel tubes comprising 4 combs at 90° to one another

6. Heel protector on the lowermost tube.

7. Electro-mechanical assembly on manual version (TRS361):

- Solenoids and cams mechanically lock the rotating obstacles in their resting position

- Compensating arm with tension springs allowing the obstacle to be repositioned after passage

- Self-adjusting oil damper for damping movement at end of the cycle

- Mechanism preventing return of obstacle after 45° rotation.

8. Electro-mechanical assembly on motorized version (TRS366):

- Obstacles driven by 24V brushless motor with a reversible reduction gear

- Pulley-toothed belt transmission

- Inductive position sensors

- “Push hand go” type movement (pushing against the rotating obstacle activates the motor drive), motor started-up when authorization given to pass, or continuous movement

- Acceleration and deceleration controlled by the motor

- Solenoids and cams mechanically lock the rotating obstacles in their resting position

- Mechanism preventing return of obstacle after 45° rotation.

9. Logical assembly:

- 24V AC control logic with general connection block

- Parameters set using digital keyboard and LCD screen

- Networked with remote controller

Operating mode:

Each passageway of the TRS361/366 can be configured in one of 5 different operating modes in each direction of passage:

1 = Free access

2 = Permanently locked

3= Locked, but free to rotate in case of power failure

4= Electrically controlled

5= Electrically controlled, but free to rotate in case of power failure

Surface treatment:

- Anti-corrosion protection:
Metal framework treated by zinc phosphating, followed by cathaphoresis (cathodic process), 20µm thick.
- Paint finish:
Powder-coated polyester finishing coat 100µm thick. RAL 7031 (dark grey) for the upper box section and RAL 7038 (light grey) for the vertical uprights and curved panels
- Internal parts:
Galvanization, cathaphoresis or anodization

Technical characteristics:

- Power supply: 230V single phase
- Control circuits: 24V AC
- Power consumption: Manual version: 100VA
Motorized version: 150 VA
- Operating temperature: -20°C to +65°C.
- Relative humidity: 95%
- MTBF: 2 years
- MCBF: 1 million operations
- MTTR: 20 minutes
- Net weight 365 kg

Conforms with the machinery, low voltage safety and electromagnetic compatibility directives according to EN60204, EN60950, EN 50081-1 and EN50082-2

Options:

- Operation by 1/8 th of a turn with intermediate blocking for dual access control
- Mobile obstacles made of nitrated AISI304 stainless steel tubes
- Hair pin mobile obstacles
- Climb-proof top section
- Roof
- Passageway lighting incorporated within the upper box section
- Orientation pictogram
- 110V 60Hz power supply
- Key-operated fireman's release
- Fixing frame to be embedded in the concrete.
- Pre-assembly of the turnstile before delivery

Work not supplied:

- 230V single phase 6A + Earth power supply and electric cable if necessary for remote control of turnstile
- Masonry work as required per general arrangement drawing

Dimensions

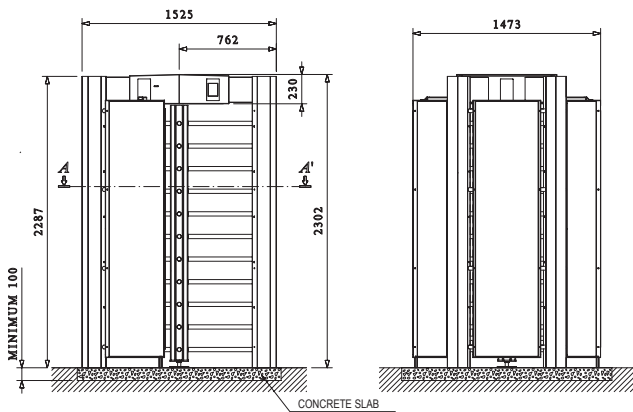

General arrangement drawing

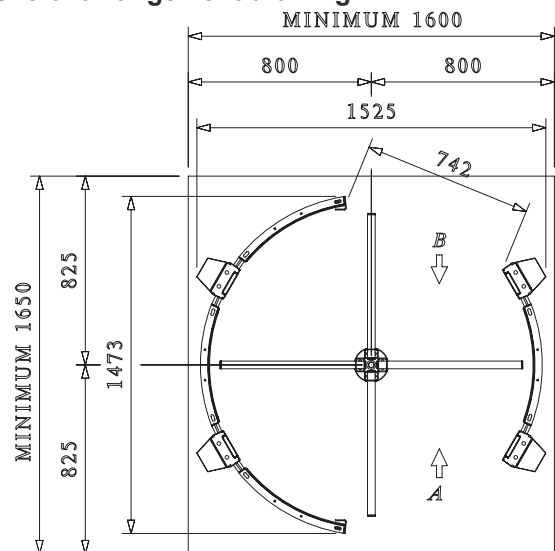

Drilling template supplied as standard.

Our dealer

EagleTech Ltd

152 Shaw Bridge, Harlow, Essex CM19 4NR
 Tel: 0845 6344 600
 Fax: 0845 6344 605
 info@eagleTechlimited.co.uk
 www.eagleTechlimited.co.uk



With a constant view of adopting the latest technological developments, Automatic Systems reserves the right to amend the information above, at any time.